

14.5' DRYWALL LIFT

- Easily and safely lifts drywall sheets up to a height of 14.5'
- Chain-driven, coupled with a manual winch and input torque limiter, which keeps the operator safe and prevents damage to the lift from overload
- This commercial-grade, heavy-duty, chain-driven lift is designed for the serious professional, making this lift the safest, longest-lasting lift on the market
- Never worry about replacing cable sheaves or cables due to the heavy-duty, chain-driven lifting mechanism



Drywall Lift

EDI	Part#	Description
28681	DWL145	14.5' Drywall Lift - Chain

Replacement Parts

EDI	Part#	Description
28893	CBA	Complete Brake Arm Assembly
28897	CASTER6	6" Caster w/ Hardware

Accessories

EDI	Part#	Description
28895	EXT18	18" Extension

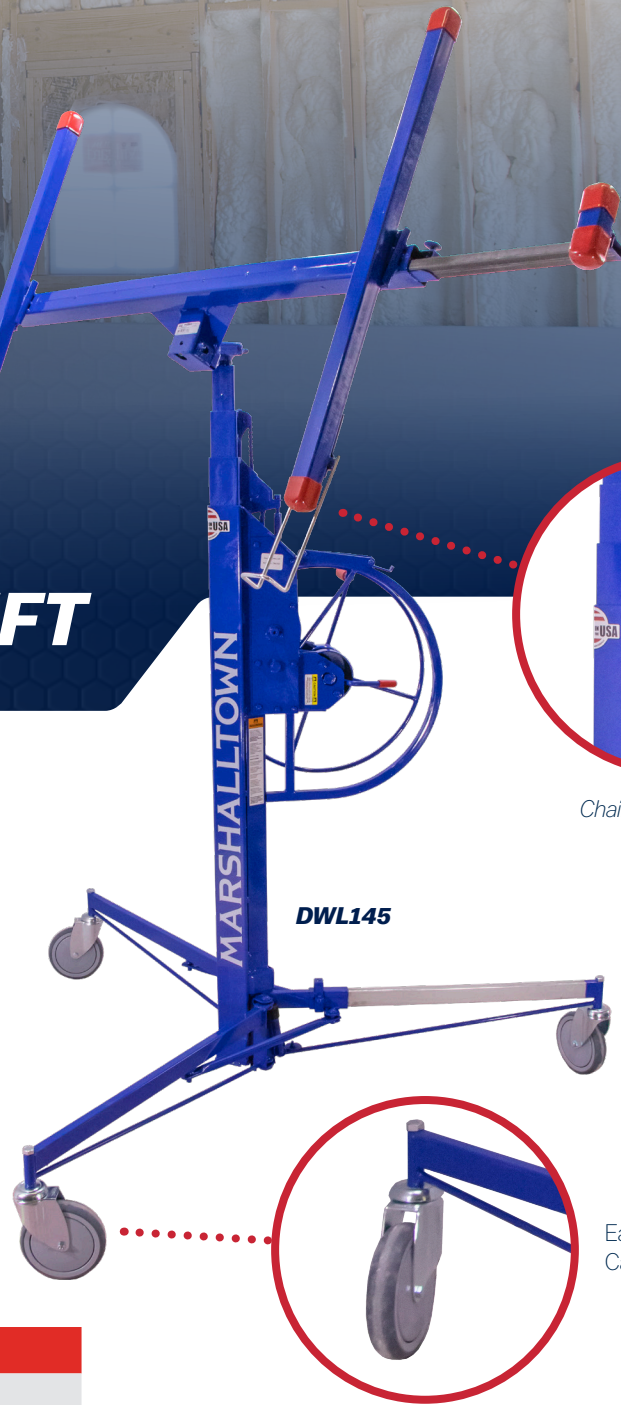

Chain-Driven Lifting

DWL145



Easy-Roll 6" Caster Wheels

Specifications

Max. Standard Reach: 14.5'
Standard Loading Height: 37"
Reach with EXT18: 15' 11"
Load Capacity: 200 lbs.
Sheet Size & Capacity: Single Drywall Sheet up to 4' x 16'
Power Source: Manual
Lift Mechanism: Multi-Stage Chain with Integrated Input Torque Limiter