



## 9" (229 mm) ULTRA-LITE FLOORING CUTTER

Part# LWFS9 | EDI# 32628



104 S. 8th Ave. | Marshalltown, IA  
Phone 800-888-0127 / 641-753-0127 | Fax 800-477-6341 / 641-753-6341  
[www.MARSHALLTOWN.com](http://www.MARSHALLTOWN.com)  
WS3430RevB

## INTRODUCTION

Congratulations on your purchase of a MARSHALLTOWN Ultra-Lite Flooring Cutter. Proudly made in the USA, MARSHALLTOWN flooring cutters are heavy-duty and manufactured with the highest-grade materials. MARSHALLTOWN cutters are designed with the flooring professional in mind to ensure accuracy and reliability.

Other features of your MARSHALLTOWN Ultra-Lite Flooring Cutter include:

- Easy, quiet one-cut action
- Ability to cut inside and produce no dust
- Cut material up to 9" (229 mm) wide and  $1\frac{5}{32}$ " (12 mm) thick

This owner's manual provides the information needed to operate and maintain this MARSHALLTOWN flooring cutter. Carefully read and follow all safety and operating instructions in this manual. Ensure every operator of this flooring cutter reads this manual before operating the unit. The replacement of any part on this flooring cutter by other than the manufacturer's authorized replacement part may adversely affect the performance, durability, or safety of the product.

**Be sure safety precautions are observed. Read and follow all safety and operating instructions in this operator's manual.** The manufacturer reserves the right to make changes on or add improvements to its product at any time without prior notice or obligation. The manufacturer reserves the right to decide, upon its sole discretion and at any time, to discontinue this product.

This manual covers the MARSHALLTOWN 9" (229 mm) Ultra-Lite Flooring Cutter. For technical questions or repair parts, please call MARSHALLTOWN customer service at 1-800-888-0127 or visit [www.MARSHALLTOWN.com](http://www.MARSHALLTOWN.com).

# TABLE OF CONTENTS

Safety Precautions.....	3
Safety Decals .....	4
Warranty.....	4
Assembly .....	5-6
Product Operation .....	7
Cutting Guide .....	7
Parts Breakdown .....	8-9
Replacement Parts .....	9
Maintenance .....	10
Troubleshooting.....	11

## SAFETY PRECAUTIONS



- DANGER or WARNING safety signs are located near specific hazards.
- General precautions are listed on CAUTION safety signs.

- This notation appears before warnings in the text. It means that the step that follows must be carried out to avoid the possibility of personal injury or death. These warnings are intended to help the technician avoid any potential hazards encountered in the normal service procedures. We strongly recommend that the reader takes advantage of the information provided to prevent personal injury or injury to others.

THE FOLLOWING PRECAUTIONS ARE SUGGESTED TO HELP PREVENT ACCIDENTS. A CAREFUL OPERATOR IS THE BEST OPERATOR. MOST ACCIDENTS CAN BE AVOIDED BY OBSERVING CERTAIN PRECAUTIONS. READ AND TAKE THE FOLLOWING PRECAUTIONS BEFORE OPERATING THIS EQUIPMENT TO HELP PREVENT ACCIDENTS. EQUIPMENT SHOULD BE OPERATED ONLY BY THOSE WHO ARE RESPONSIBLE AND INSTRUCTED TO DO SO.



**CALIFORNIA PROPOSITION 65 WARNING:** This product can expose you to chemicals known to the State of California to cause cancer, birth defects, or other reproductive harm.

- Read all operating and maintenance instructions before operating or servicing the flooring cutter.
- A flooring cutter is only as safe as its operator. Give complete and undivided attention to the operation of the flooring cutter.
- Know how to stop the flooring cutter instantly.



**NEVER** operate the flooring cutter if any cutter components have been removed.

- Keep inexperienced and unauthorized people away from the flooring cutter at all times.
- Keep the flooring cutter in good operational condition. Loose or damaged parts are dangerous.
- Avoid loose clothing that could get caught in moving parts.



Keep hands and feet away from moving parts.

- Keep all warning, caution and safety instruction labels in good condition. Replace missing, damaged or illegible labels.
- Clear the work area around the cutter to prevent tripping or falling onto the cutter.
- Operate on level ground to prevent the flooring cutter from flipping over.
- DO NOT OPERATE this flooring cutter under the influence of alcohol or while taking medication that impairs your reactions.
- Use only factory authorized parts for replacement.
- Wear safety glasses when operating the flooring cutter.
- Always use caution when replacing the cutter blade.
- Only operate the cutter with the approved materials. If extreme force is required to cut a material, it may result in personal injury and/or damage to the flooring cutter.
- Wear proper protective clothing while operating flooring cutter, including eye, ear, and clothing.
- Handle all solvents and cleaning agents with care and follow manufacturer's instructions on safety and disposal.

## SAFETY DECALS

If your safety decals are damaged, they can be replaced by contacting Customer Service.



R6338

## WARRANTY

This product is warranted to the original purchaser only, to be free of defects in material and workmanship under normal use, for one year from purchase date. MARSHALLTOWN shall without charge for parts and labor, repair or replace such parts which are found to be defective. All transportation charges for replacement parts must be borne by the purchaser.

For warranty service, the product must be delivered, with proof of purchase date, to MARSHALLTOWN. Contact MARSHALLTOWN Customer Service to determine the best method of delivering the product that is under warranty. The delivery of the product must be made no later than 30 days after the expiration of the warranty period.

All implied warranties, including those of merchantability and fitness for a particular purpose, are limited to one year from date of purchase by the original retail customer and to the extent permitted by law any and all implied warranties are excluded and disclaimed after the expiration of such period.

Some states do not allow limitations on how long an implied warranty lasts, or the exclusion or limitations of incidental or consequential damages, so the above limitations or exclusions may not apply to you. This warranty gives you specific legal rights, and you may also have other rights, which vary from state to state.

Exclusion from this warranty:

1. All consequential damages, including pickup and delivery of the unit, communication, mileage charges and/or rental of a replacement unit during repairs are not covered under this warranty, or are any loss of income and/or other loss resulting from the failure of the product to function due to a warranty defect.
2. This warranty will not apply when the product becomes inoperative due to misuse, normal wear, neglect, improper maintenance, or freight damage; has not been operated and maintained in accordance with the instructions furnished in the Operator's Manual; or has been altered or modified without approval from the factory Service Department.
3. No parts or products are to be returned to the factory without prior written approval from the factory.

# ASSEMBLY

1. Lay out all of the parts.

Tools for Assembly:

- #2 Phillips Screwdriver (not included)
- $\frac{5}{32}$ " Hex Wrench (included)
- $\frac{7}{32}$ " Hex Wrench (included)

- A. Bed
- B. Leg
- C. Bed Brace
- D. Handle
- E. Bed Fence
- F. Cutter Assembly

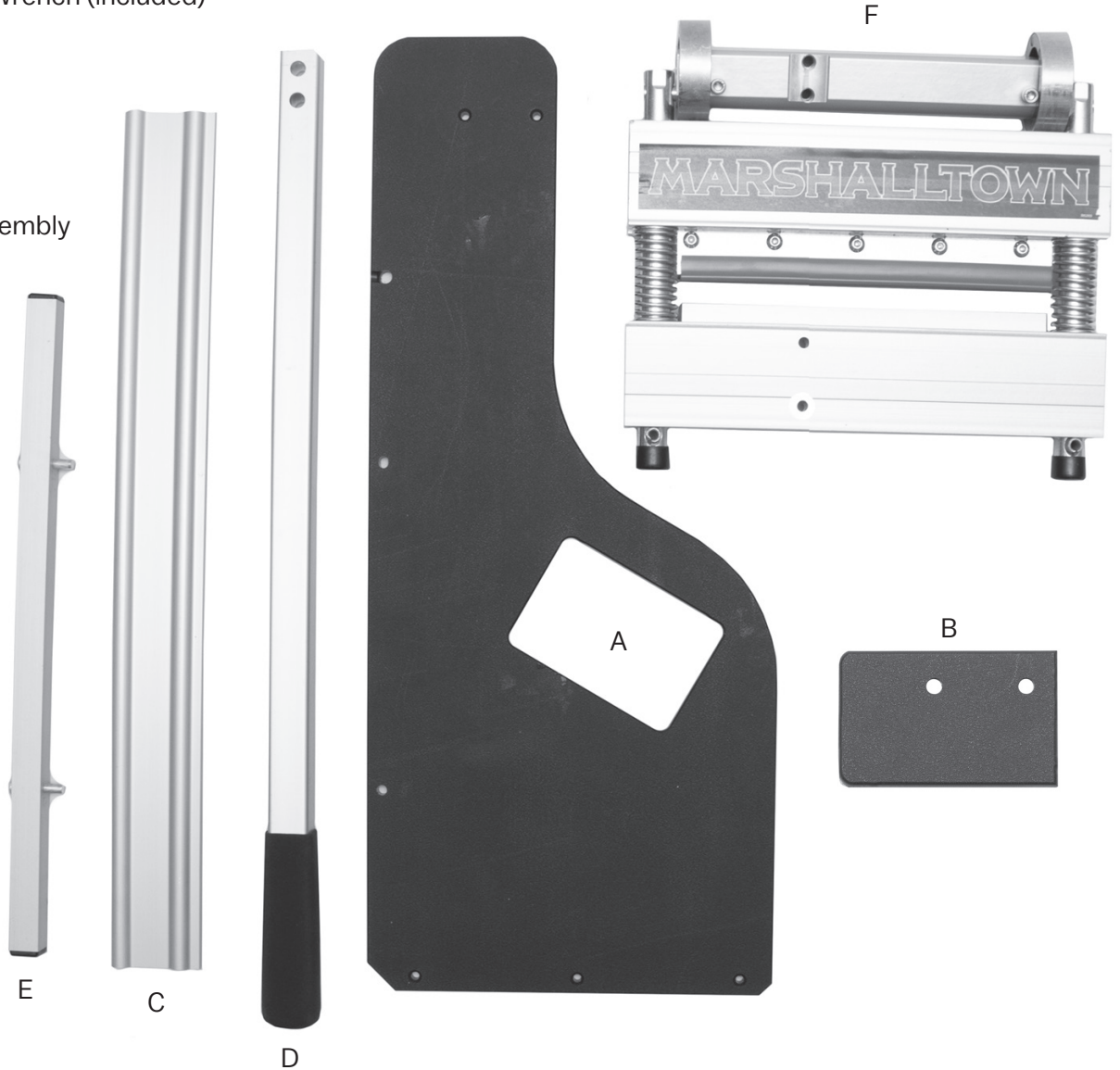

2. Lay out all hardware.

- G. Cam Locking Pin (1x)
- H. #2 Phillips Drive, Flat Head Screw, 10-24 X  $\frac{3}{4}$ " (3x)
- I. #2 Phillips Drive, #10 Flat Head Screw, 1" Long (2x)
- J. Cutting Torx BHCS  $\frac{1}{4}$  - 20 X 1" (2x)
- K. Cutting Torx BHCS  $\frac{1}{4}$  - 20 X 2 $\frac{1}{2}$ " (2x)
- L.  $\frac{7}{32}$ " Hex Drive Button Head Screw,  $\frac{3}{8}$ "-16 X 1 $\frac{1}{4}$ " (2x)
- M. Honing Stone (1x)

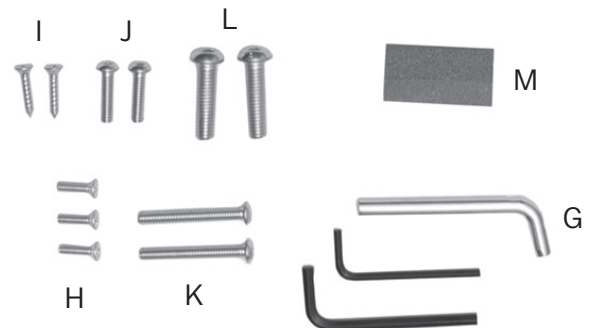

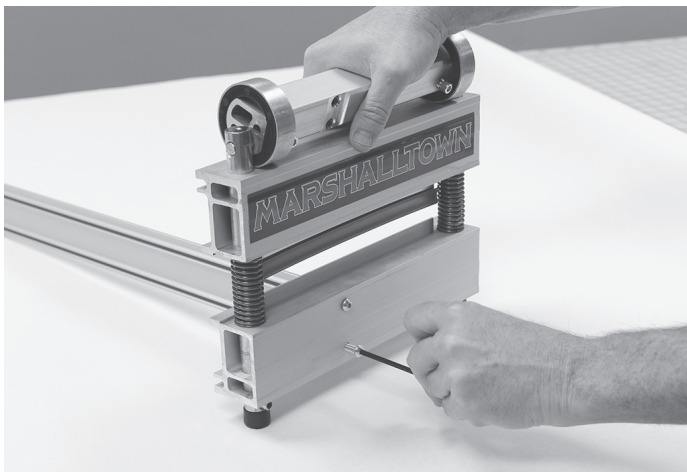

3. Attach the Bed Brace (C) and Cutter Assembly (F) using Hardware Set (K).

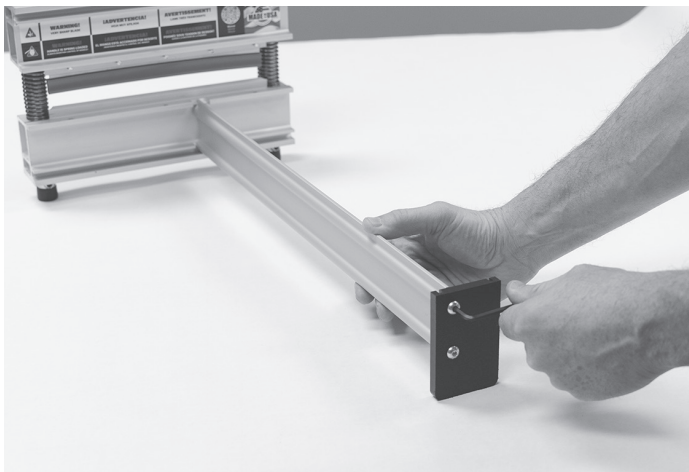

4. Attach the Leg (B) to the other side of the Bed Brace (C) using Hardware Set (J).

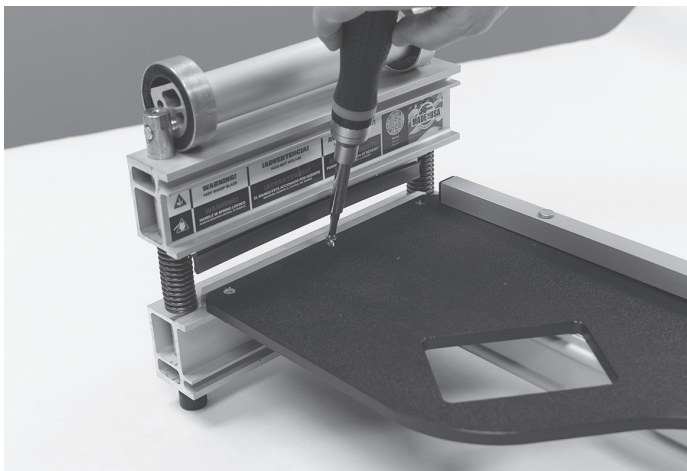

5. Attach the Bed (A) to the Cutter Assembly (F) using Hardware Set (I) for the back and Hardware Set (H) for the front.



6. Rotate the Handle Base on the top of the Cutter Assembly (F) and insert the Locking Pin (G) into the side.



7. Attach Handle (D) to the Handle Base using Hardware Set (L).

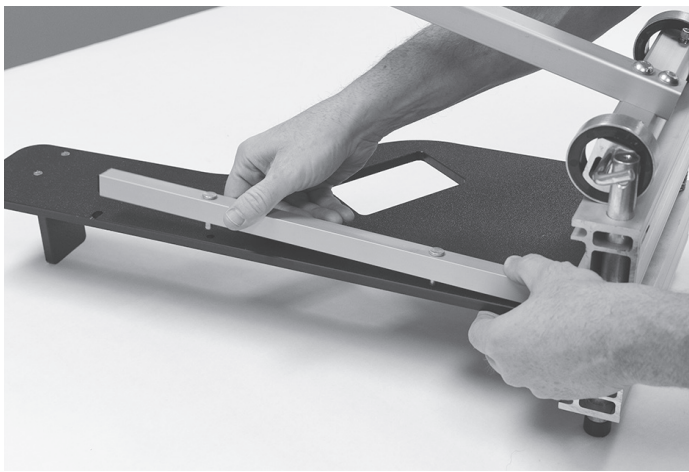

8. Place the Bed Fence (E) into the holes on the right side of the Bed (A).

## PRODUCT OPERATION

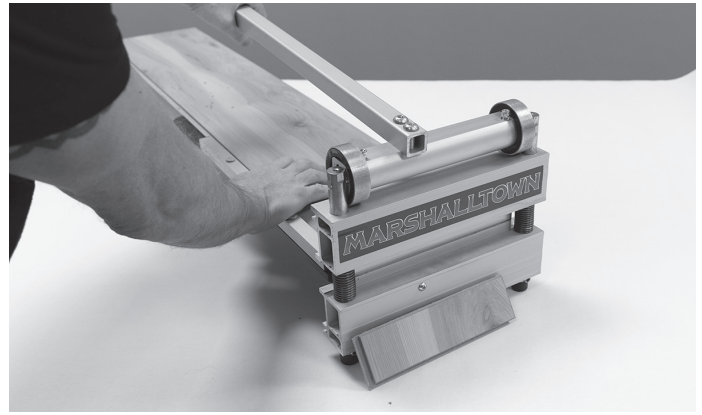

1. Press down handle and carefully remove the Cam Locking Pin. Carefully raise and release the handle.
2. Place material to be cut on the table with the finished side up and slide past the blade to the desired length. Press flooring against the Bed Fence and hold firmly in place to ensure a clean and accurate cut. Press handle down until the blade touches the material and then firmly press down on the handle until the material is cut.

## DOUBLE CUTTING

Some materials may require the double cutting method to obtain a clean cut. For these materials, make your first cut  $\frac{1}{4}$ " longer than your mark. Then, make a second cut on your mark. This method will help produce cleaner cuts on some materials.

## CUTTING GUIDE

The MARSHALLTOWN 9" Ultra-Lite Flooring Cutter is designed to cut a variety of materials. Some of the most common materials are laminate flooring, engineered hardwood, luxury vinyl tile, luxury vinyl plank, vinyl composite tile, fiber cement board siding, and more.

**Note: DO NOT attempt to cut any solid wood, high pressure laminate, engineered hardwood with a Janka Hardness Rating higher than 1200 or a rating higher than AC4.**

Note: Even the approved materials may vary greatly in density and hardness. If extreme force is required to cut a material stop immediately, as it could lead to damage to your cutter or injury. Attempting to cut unapproved materials will void the warranty.

# PARTS BREAKDOWN

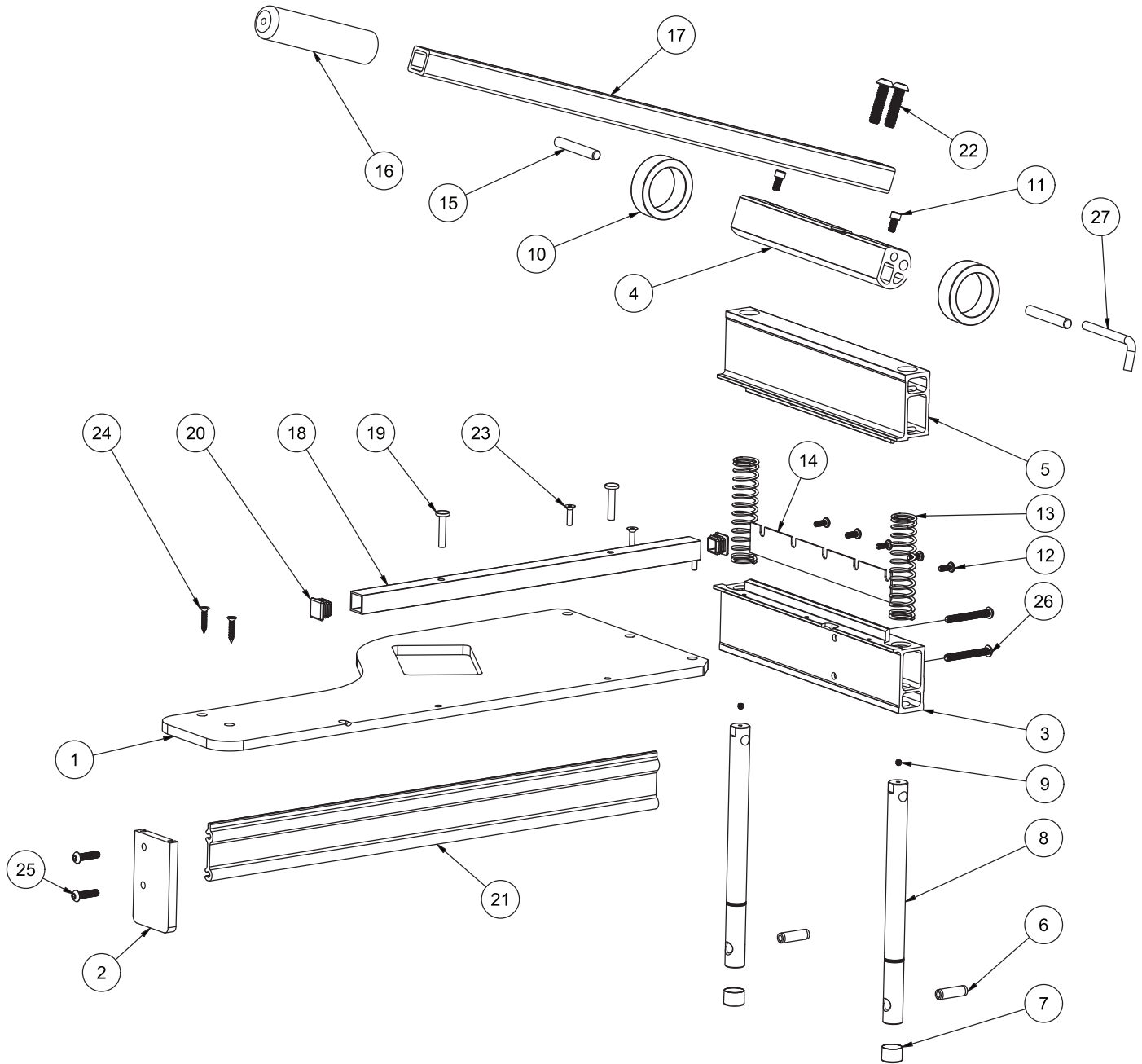



## PARTS BREAKDOWN

REF #	DESCRIPTION	PART#	Quantity
1	BED - ULTRA-LITE FLOORING CUTTER, 9"	R4633	1
2	LEG - ULTRA-LITE FLOORING CUTTER, 9"	R4634	1
3	ANVIL BEAM - ULTRA-LITE FLOORING CUTTER, 9"	R0080	1
4	CAM BAR - ULTRA-LITE FLOORING CUTTER, 9"	R5299	1
5	BLADE BEAM - ULTRA-LITE FLOORING CUTTER, 9"	R0079	1
6	SPRING PIN, ZN PL SLOTTED, 0.375 DIA X 1¼" LONG	WR1379	2
7	¾" ROUND END CAP	WL793	2
8	GUIDE ROD - ULTRA-LITE FLOORING CUTTER, 9"	WU913	2
9	SET SCREW - 10-24 UNC, ¾" LONG	WR1377	2
10	BEARING ASSEMBLY-LWFS	R7363	2
11	SHCS, ¼-20 X ½"	WR1427	2
12	PPH MACHINE SCREW, 10-24 X ½" Z	WR1158	5
13	SPRING - COMPRESSION - 0.970" OD x 4" LONG, 14 lbs./in.	WR1634	2
14	CUTTER BLADE - ULTRA-LITE FLOORING CUTTER, 9"	LWFS9B	1
15	CAM PIN-ZINC PLATED	WU905	2
16	1½" HANDLE GRIP (GRIP WORKS PART #133456)	WT507	1
17	HANDLE - ULTRA-LITE FLOORING CUTTER, 9"	R5869	1
18	FENCE - ULTRA-LITE FLOORING CUTTER, 9"	R4589-010	1
19	¼ x 1¼ AL FLAT HEAD SOLID RIVET	WR1553	2
20	SQUARE PLASTIC CAP	WL790	2
21	BED BRACE - ULTRA-LITE FLOORING CUTTER, 9"	WC947	1
22	BHCS ¾-16 X 1¼" LONG, ZINC PLATED	WR1443	2
23	FHCS, 10-24 UNC, ¾" LONG	WR1384	3
24	#10 FLAT HEAD PHILLIPS SCREW - 1" LONG	WR1381	2
25	CUTTING TORX BHCS ¼ - 20 X 1"	WR1892	2
26	CUTTING TORX BHCS ¼ - 20 X 2 ½ "	WR1584	2
27	CAM LOCK-ZINC PLATED	WU904	1

## REPLACEMENT PARTS

REF #	DESCRIPTION	EDI
14	REPLACEMENT BLADE	32629
16, 17	REPLACEMENT HANDLE	32630
N/A	HONING STONE	28901
27	CAM LOCK PIN	28905
7	SLIP ON FOOT	29855
9, 15	CAM PINS AND SET SCREWS	33182
18, 19, 20	BED FENCE	R4589

# MAINTENANCE

## Honing the Blade

Press the handle down and insert the cam locking pin. Place the provided Honing Stone (M) against the flat side of the blade. Slide the honing stone from one end of the blade to the other 3-4 times. This will remove any burrs from your blade. After the break-in period, hone every 100 cuts. Use caution when honing the blade. The blade is sharp and can easily cause injury. Cut-resistant gloves are recommended when honing the blade.



## Break-in Period for New Blades:

1. Hone after 1 cut.
2. Hone after 5 cuts.
3. Hone after 10 cuts.

## Replacing the Blade

 Use cut-resistant gloves when replacing the blade. **CAUTION!** Cover the cutting edge with a blade guard or other suitable covering. Place the cutter upside down on a workbench with the jaws in the open position, creating a gap to allow blade removal. To remove the blade use a #2 Phillips screwdriver and loosen the 5 retaining screws one full turn counterclockwise. When the last screw is loosened, the blade will slip out. Remove the screws if the blade does not slip out easily. Cover the cutting edge of the new blade with a blade guard or other suitable covering. Slide the new blade into position with the beveled edge facing the screws. Center the blade and make sure the blade is fully inserted. Hand-tighten the center screw. Hand-tighten the remaining screws to complete the installation.

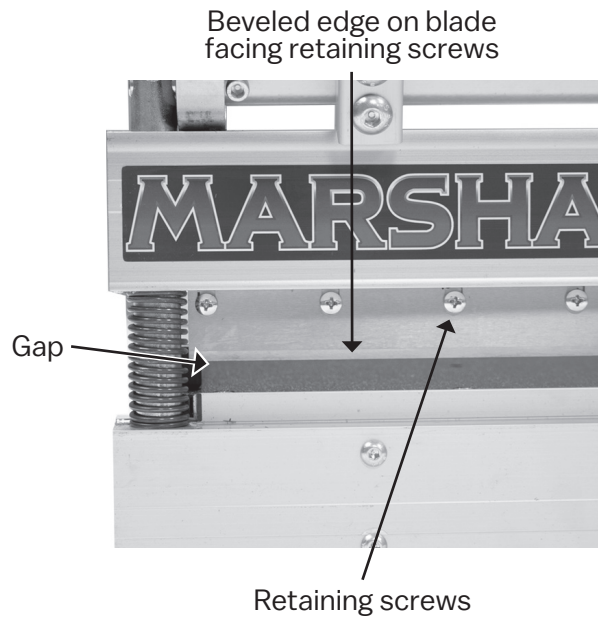

## Lubrication

After every 100 cuts, it is recommended that the cutter be lubricated. Use a light oil and grease (wheel bearing grease) and apply according to the image below. Lubricating the cutter will extend the life of the cutter and result in easier cutting.

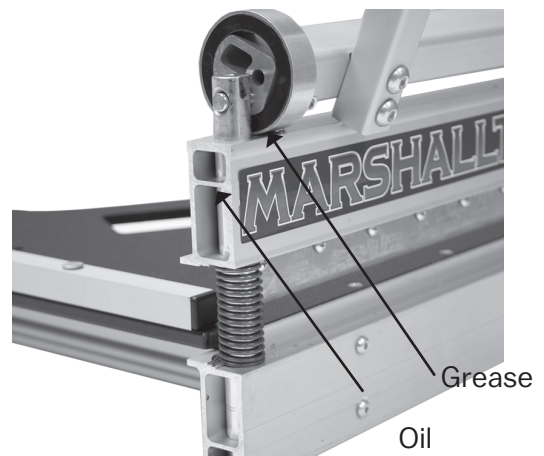

## TROUBLESHOOTING

ISSUE	RESOLUTION
Cutter won't cut desired material	Review cutting guide in manual to confirm it is a confirmed material. Contact MARSHALLTOWN customer service. <b>Do not attempt to use extreme force to cut the material.</b>
Cutter is leaving a jagged edge on flooring	Use honing stone to carefully touch up the blade as described in the manual. Use double cutting method as described in the manual if necessary.
Cutter requires more force to cut than normal	Use honing stone to carefully touch up the blade as described in the manual. Follow the maintenance section of the manual to oil and grease the cutter.



104 S. 8th Ave., Marshalltown, IA  
Phone 800-888-0127 / 641-753-0127  
Fax 800-477-6341 / 641-753-6341  
[www.MARSHALLTOWN.com](http://www.MARSHALLTOWN.com)  
WS3430RevB