

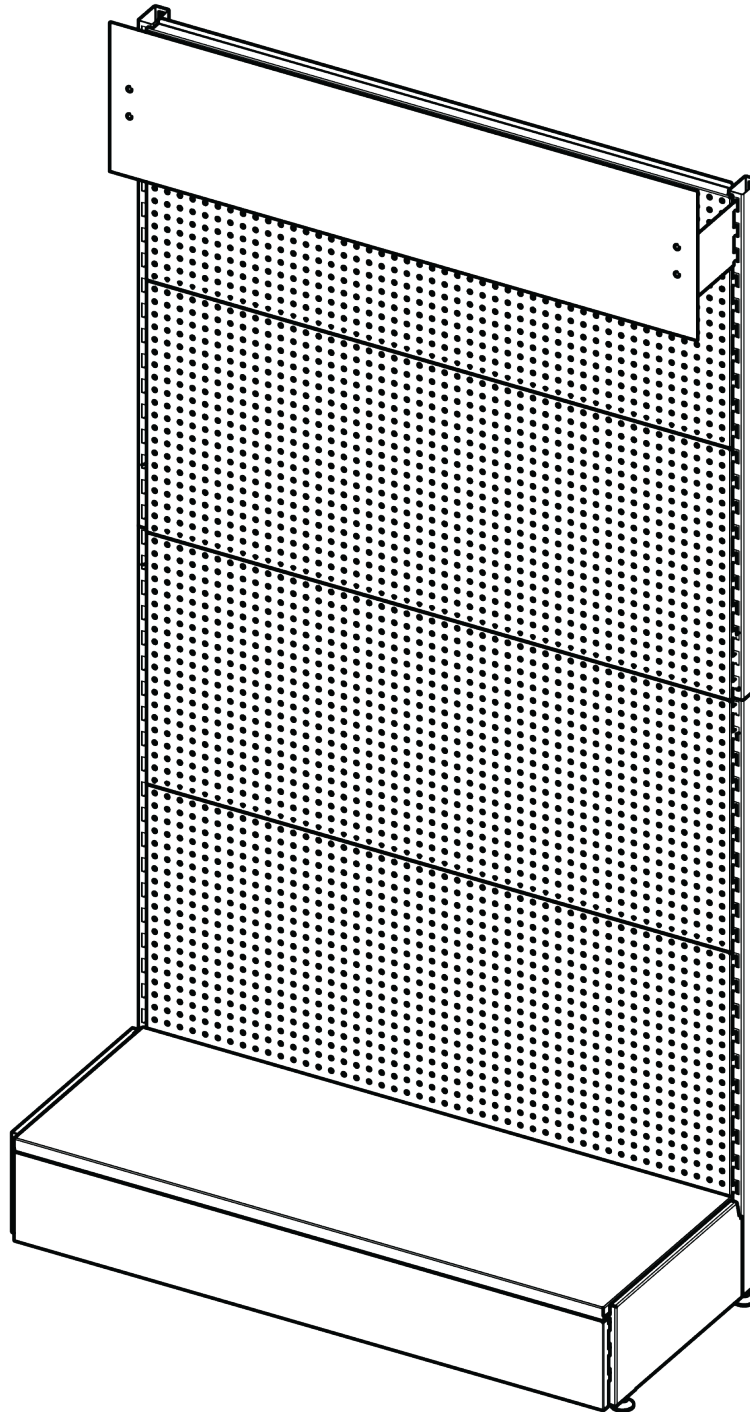

# 4' GONDOLA WITH MARSHALLTOWN HEADER SIGN

GONDICB | EDI# 33471



# WARRANTY

This product is warranted to the original purchaser only, to be free of defects in material and workmanship under normal use, for one year from purchase date. MARSHALLTOWN shall without charge for parts and labor, repair or replace such parts which are found to be defective. All transportation charges for replacement parts must be borne by the purchaser.

For warranty service, the product must be delivered, with proof of purchase date, to MARSHALLTOWN. Contact MARSHALLTOWN Customer Service to determine the best method of delivering the product that is under warranty. The delivery of the product must be made no later than 30 days after the expiration of the warranty period. All implied warranties, including those of merchantability and fitness for a particular purpose, are limited to one year from date of purchase by the original retail customer and to the extent permitted by law any and all implied warranties are excluded and disclaimed after the expiration of such period. Some states do not allow limitations on how long an implied warranty lasts, or the exclusion or limitations of incidental or consequential damages, so the above limitations or exclusions may not apply to you. This warranty gives you specific legal rights, and you may also have other rights, which vary from state to state.

Exclusion from this warranty:

1. All consequential damages, including pickup and delivery of the unit, communication, mileage charges and/ or rental of a replacement unit during repairs are not covered under this warranty, or are any loss of income and/ or other loss resulting from the failure of the product to function due to a warranty defect.
2. This warranty will not apply when the product becomes inoperative due to misuse, normal wear, neglect, improper maintenance, accident or freight damage; has not been operated and maintained in accordance with instructions furnished in the Operator's Manual; or has been altered or modified without approval from the factory Service Department.
3. No parts or products are to be returned to the factory without prior written approval from the factory.

## SAFETY PRECAUTIONS



• DANGER or



WARNING safety signs are located near specific hazards.



• General precautions are listed on CAUTION safety signs.

- Do not assemble unless all the parts are available. A unit without all the parts may not be stable.
- Inspect parts before assembly. Do not assemble using damaged parts.
- Do not assemble using parts not meant for this display.
- Do not stand or climb on the unit. It was not designed for such weight.
- Load the display evenly with product.
- Do not modify hooks to fit in display peg hook holes.
- This assembly is a two-person job.
- When assembling, use proper step stools or ladders.
- Make sure the display is level when assembled. Use the feet on the bottom of the display to level the unit if necessary.

CONTENTS		QTY
<b>A</b>	Gondola Leveling Feet	4
<b>B</b>	Header Push Pins	4

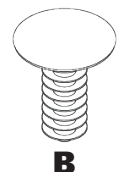
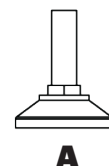

# ASSEMBLY

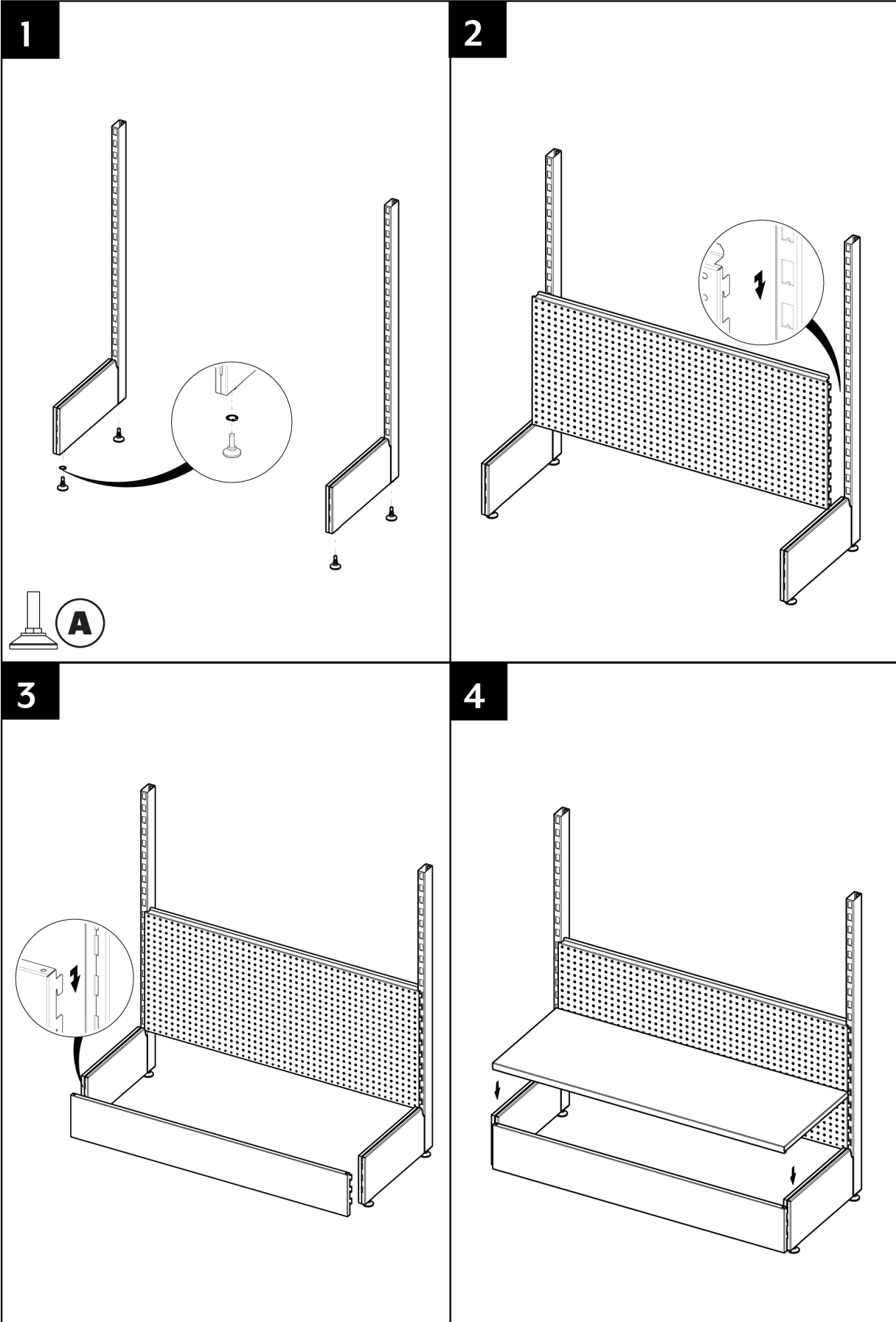

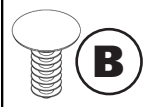
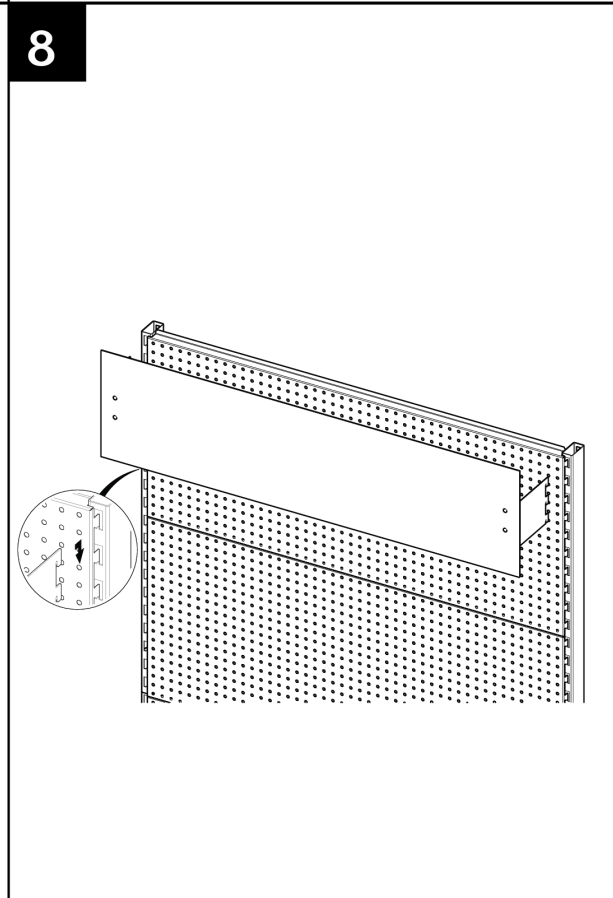
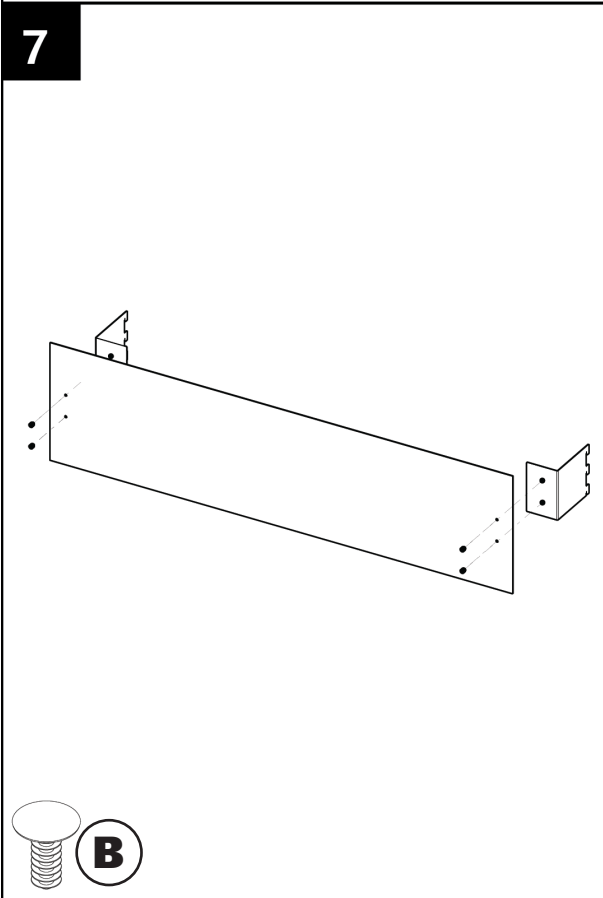
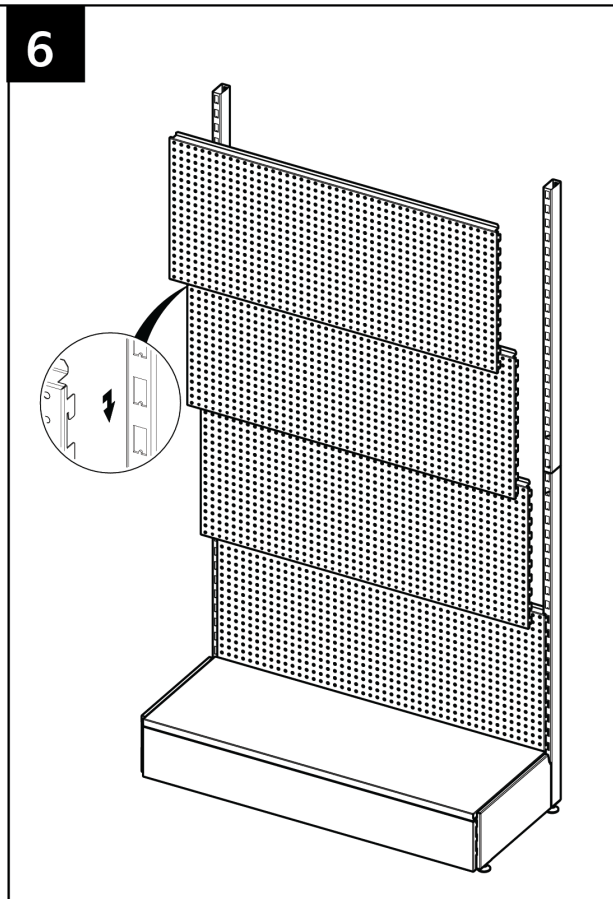
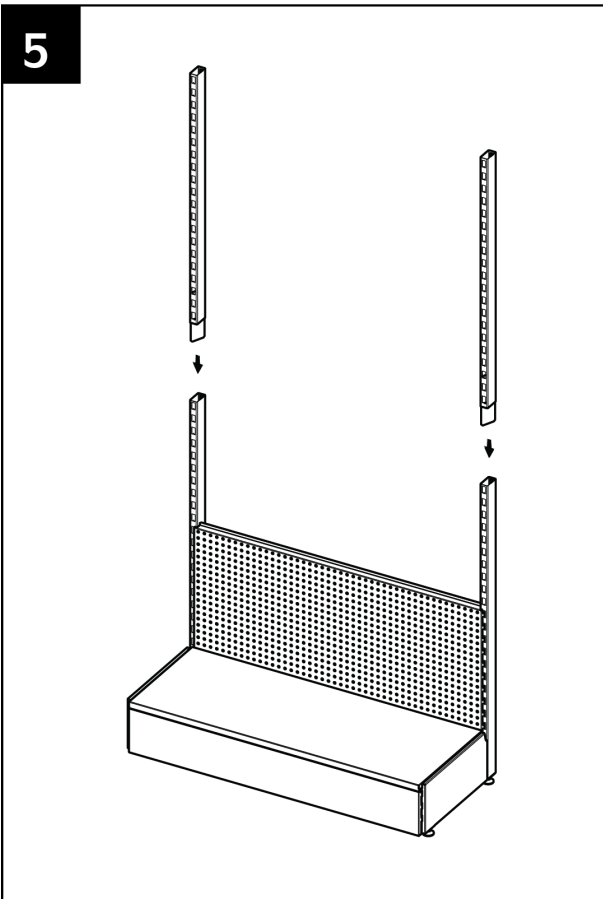



104 S. 8th Ave., Marshalltown, IA  
Phone 800-888-0127 / 641-753-0127  
Fax 800-477-6341 / 641-753-6341  
[www.MARSHALLTOWN.com](http://www.MARSHALLTOWN.com)  
WS4847